

Solar Source

Electronic Control System & Wall Switch Operation



Product version ref 1.3, October 2008



Wall Switch plate



Controller unit

GENERAL OPERATION

The Solar Source products are designed to be left running all the time – set and forget. Generally during warmer weather, the system is set to COOL and the fans to Low or High and alternatively during cooler weather the system is set to HEAT. The fans can be turned off if required, but if the system is set to COOL and fans to Low, then the building will at least have some ongoing ventilation even if no one is in the building.

In the heart of the system is a controller box that will operate the fans and direct the flow of air to the appropriate place as the operator has requested. The behavior of the system will vary somewhat, depending upon the options that have been purchased with the system.

All Solar Source products come with the same Electronic Control System and Wall Switch. This enables all systems to be upgraded and interchangeable.

THE FAN BUTTON

There are two air-flow settings that can be adjusted by the operator from the white wall plate within the building.

- When the FAN button is pressed once, the LOW fan setting is selected and the wall panel will beep once.
- If this button is pressed a second time, the HIGH speed fan setting is engaged and two beeps may be heard.
- A red LED indicator will show which fan speed is presently selected.
- Pressing the FAN button a third time will make the wall panel sound one long-beep and turn the fan system to OFF.

If there is insufficient sunlight to heat up the air and drive the fans, the led indicator will flash slowly until sufficient sunlight returns.

THE HEAT/COOL BUTTON

The second button on the wall control is used to select which air source is being directed into the building. Some Solar Source installations have a choice between heated air from the solar collector, or cooler air drawn from another location. The COOL mode may allow the system to work at night if the optional 240V power supply has been fitted to the system.

THE CONTROL UNIT BATTERY

Inside the controller box is a rechargeable battery that will draw from the solar panel or power supply to automatically maintain itself. It is not used to supply power to the fans, its main function is to operate the led indicators on the wall plate after dark where the 240V power supply option has not been supplied. Where the dual Heat-Cool modes are both installed, the battery also provides power to permit the electric vent control to change the air flow path.

Very early on some mornings, when daylight first reaches the electric Solar Panel, the fan indicator will flash rapidly for 40 minutes before the fans actually start if a fan has been set to *Low* or *High* the night before. This is a settling time where the solar air collector is warming up and an extra charge is being directed to the battery from the electric solar panel.

The battery should last for 4 years with normal operation and can be changed by the installer. If the 240V supply option has been installed and the mains power is reasonably reliable, the backup battery may not be required.

ADDITIONAL USER INFORMATION

If the LED lights are blinking slowly it indicates that there is not enough sunlight to activate the fans, but the fans will switch on once enough sunlight is available.

If the LED lights are blinking quickly it indicates that the internal battery is being charged. This occurs for 40 minutes at dawn, typically before sufficient sunlight is present to power the fans. You can override this by pressing any of the wall control buttons and the system will commence normal operation. Note that this dawn charge cycle does not take place if an external power supply is fitted as this supply will also float-charge the battery.

If the switch is set to COOL and you have the optional 240/12 volt plug pack connected to mains power, the fans will continue to operate at night. The fans may be switched off at any time if they are not needed.

DETAILED OPERATION NOTES FOR THE INSTALLER

This section provides a detailed description Solar Source operation. While this is not essential information for operators, it will be of assistance to the installer for a greater understanding of how the software within the control box manages the system.

DAY - NIGHT MODES

It is important that the control system is aware whether or not useful sunlight is present. It does this by measuring the output of the solar panel. To reduce the amount of hunting back and forth with cloud cover, there is a fairly wide gap in the voltage thresholds from the Solar Panel that determine the Day/Night mode selections.

- When a controller is first connected up by the installer, the NIGHT MODE is assumed.
- If the Solar Panel Output rises above 17V for more than 20 seconds, it decides that useful sunlight is present and the DAY MODE is assumed.
(Note that if the DC supply has been fitted, the 17V threshold is automatically reduced to a 13V threshold to compensate for the extra loading the solar panel will encounter)
- If the Solar Panel output falls below 6V for more than 20 seconds, it must be on a darkened state and the NIGHT MODE is assumed.
- The controller performs **NO** battery charging checks during the DAY & NIGHT MODE.
- Unless the optional DC Power Supply has been fitted, the fans will NOT try to operate during the NIGHT MODE. If the operator *does* try to activate a fan, the Fan Led will flash slowly to indicate insufficient daylight to operate the system.

HEAT/COOL MODES

There are two modes of operation that affect air flow. These are called HEAT and COOL and they relate to the position of the air-flow control box. The small Servomotor inside the air-flow control box will place the metal flap on one of two positions as selected by the controller box.

- When a controller is first connected up by the installer, the HEAT MODE is assumed and the HEAT indicator will be ON.
- Pressing the HEAT/COOL button will alternate the air flow control box between the HEAT and COOL states.
- Unless the optional DC power supply is connected, the fans will only run in the HEAT mode. (as in the COOL mode there would be no sun available to operate the fans.)
- If the DC power supply has been fitted the fans will run in the COOL mode at any time, and run in the HEAT mode if any useful sunlight is available.
- If in the HEAT mode and useful sunlight is NOT available, the FAN LOW and FAN HIGH leds will just slowly flash, even if the optional DC Power supply is fitted.
(This can be overridden by shifting link **LK1** inside the controller unit to the 'B' position.)

INTERNAL OPTION LINK

Internal option link, **LK1** is a small black option link inside the controller (adjacent to the battery) that may be removed and replaced in either the **A** or **B** position as labelled on the board. The default position is Position '**A**'. If the system is being used for air shifting between rooms, rather than using the sun to heat air, the DC power supply would be fitted and shifting the link to the **B** position will allow the fans to run at any time.

BATTERY CHARGING

If the DC power supply is permanently plugged into the controller, the internal battery is performing few tasks other than remembering the present operator fan & duct position settings if a mains power failure should ever occur. If mains power is reliable, it is possible to omit the battery entirely with no further impact to the system.

The controller battery is a common **12V, 1.2 a/h** sealed lead-acid (SLA) unit. The controller will manage the battery charging by only connecting it to the system when necessary.

- Unless the optional DC power supply has been fitted, the battery will remain disconnected at NIGHT and no battery integrity checks will be made.
- If a 12V DC power supply has been fitted to the system, the battery will remain connected to the controller during the DAY, even if fans are running.
- If the fans are running on either **Hi** or **Low** speed (and no DC power supply is present) then the battery is disconnected from the controller. This is because even under bright sunlight, a fan will drag the Solar Panel output below the level where it can charge the battery.

IMPORTANT!

It is essential that the Solar panel and the optional DC power supply are plugged into their correct sockets within the man Controller Unit, as labelled. Should these connectors be reversed, the system will never achieve the 'Daytime Mode' (fan leds will always flash) and the internal battery will be at risk of over-charging by the solar panel.

SPECIAL DAWN BATTERY CHARGE CYCLE

If the operator has a routine of just manually running the fan for heating from time to time, then the controller will automatically use some dawn daylight energy (while the fans are still OFF) to maintain a sufficient charge in the battery.

There was a perceived difficulty in battery maintenance in a Heating Only system where the operator simply left the fan on **HI** or **LOW** for extended periods of days or weeks without touching the controls. In this situation the battery would not charge at night (because it is dark), and it would not get to charge during the day, as the battery would not receive a useful charging voltage while fans are running. After about 5-8 consecutive days of this, (depending upon battery condition) the battery would have been discharged.

A special automatic '**Dawn Charge**' cycle of 40 minutes has been added to the system in Software Version 1.1 and above to prevent a full battery discharge from occurring. It is likely that the operator will never be aware of this 'Dawn Charge' cycle ever taking place as it only occurs for the first 40 minutes of daylight each morning if two pre-conditions have been met:

1. There must be no DC power supply presently connected to the system.
2. It must have been dark for at least 4 consecutive hours.
(This prevents this special dawn charge cycle from occurring if passing clouds and shadows over the Solar Panel cause a brief transition into the Night Node).

Note that when a system is activated for the first time, or the battery was turned Off then On again, that the system assumes that it has already had 4 hours of darkness and will attempt to run a Dawn Charge cycle when the solar panel is connected during daytime. This cycle can be bypassed by pressing either of the wall control buttons.

A typical **Dawn Charge** event would follow this sequence:

The operator has gone to bed, but left the fan in **Hi** or **Low** speed setting because they would like the system to warm up the house early in the morning. As it is dark the fans would be off at this time and the **Hi/Low** indicator would be slowly flashing.

At dawn the first light of the day reaches the electric Solar Panel. As there is no load upon the panel, it will quickly rise in output towards 19-20V. As soon as more than 17V is produced by the panel for 20 consecutive seconds, 'DAY MODE' will be engaged, but the fans won't run just yet. (This process will happen even on an overcast morning)

The Battery will connect to the panel and **stay connected for a fixed 40 minutes**. (It would not overcharge at this time as the dawn light it is still only relatively weak and interrupted by shadows) The fan LED that had been slowly flashing will change to a rapid flash during this 40 minute charging period to indicate the **Dawn Charge** event, although this process would usually pass unnoticed by the operator.

At the end of the 40minute cycle, the fans would activate normally and begin to pump warm air into the house. This 40minute charge cycle should be sufficient to sustain the battery for another 24-48 hours, even if the fan was operating all day, as the battery is always isolated from the solar panel when the fans are active to prevent the fan motors from discharging the battery.

There is positive aspect to this dawn charge cycle. The Solar Air heater would normally be stone cold at the time when daylight first reaches the electric solar panel. This 40 minute delay will give the air inside the Solar Air Heater time to heat up somewhat, so that the first air to enter the building in the morning will be warm rather than cold.

If the operator *does* observe the rapid flash of a Fan LED indicator in the morning and wishes to override the 40 minute timer, pressing either button on the wall control panel will cancel any remaining minutes of the timer and the system will just follow whatever setting the operator has selected.

BACKUP MEMORY FEATURE

Independent of the 12V backup battery, the controller also stores information about fan speed and heating modes in a special non-volatile memory every time a button is pressed. This means that even if the battery were to be disconnected and power is cut, the present fan settings will resume their previous state when power from the solar panel or power supply returns.

FUNCTIONAL TESTING

After the system has been installed, the installer should perform a functional test to ensure normal operation is occurring.

Should any aspect of the system not function normally, then the following troubleshooting section of this manual should be consulted.

'SNAIL' VERSION WITH INTEGRATED FAN & DUCT CONTROL HARDWARE

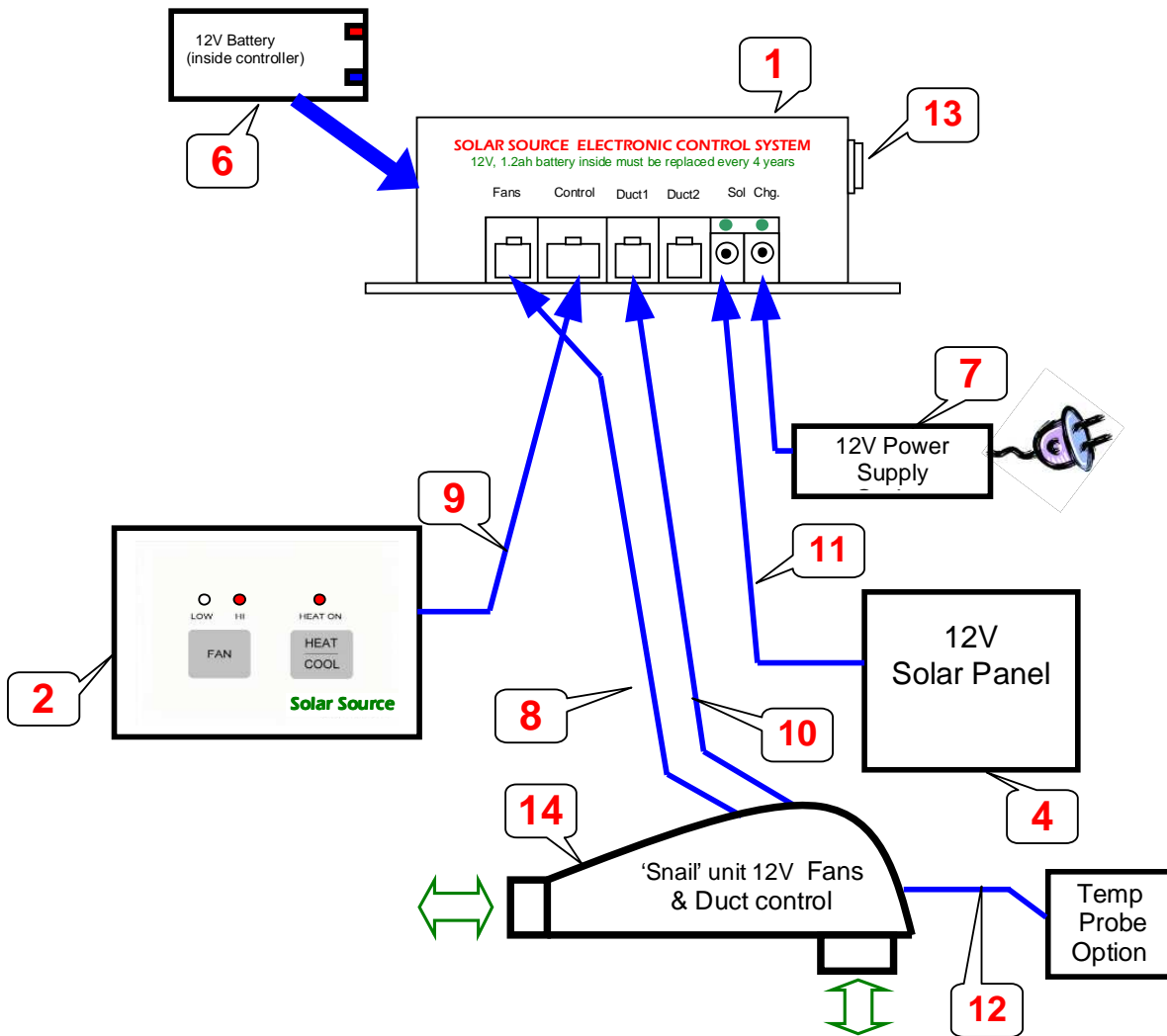

Wide and narrow views showing external connections to the underside of Item 14, the 'snail' unit.



1. **Main Controller unit**
This is the core of the system that connects the solar panel to the fans when needed. It also contains the 12V battery (item 6).
2. **Wall Control Switch**
This switch activates the fans High / Low/ Off and selects the Heat / Cool modes. It is usually mounted on a wall at a convenient location within the interior of the building.

3. **Fan Box**
This contains 4 x 12V fans operating in pairs for High & Low air flow selections.
4. **Solar Panel**
Also called 'PV' for Photo-Voltaic panel, it generates approximately 12V of power when placed in direct sunlight. (if fans are OFF, this may reach 20V on bright days)
5. **Air Flow Selection Box**
This unit selects either of two sources of air flow depending upon the position of an internal flap, which is driven into a Heat/Cool position by an internal servomotor mechanism. The position is managed by the Main Controller unit (**Item 1**). It only draws power while the servomotor moves between the two positions
6. **12Volt Rechargeable Battery**
Located inside the Main Controller Unit (item 1), this battery provides backup power to the logic circuits. It is automatically charged and maintained by the Solar Panel (**item 4**) The **On/Off** switch on the side of the controller must be in the **ON** position for the battery to work.
7. **12V Power Supply option**
Used mostly during Cooling Modes, this unit provides 12V power to the system fans from a 240V mains supply whenever the solar panel is not available. It has a round D.C. plug that connects to the **CHG** socket of the **Main Control Unit**. When connected correctly to power, then the green confirmation light above the CHG socket on the Main Controller Unit should glow.
8. **6 wire flat 'Fan' Cable**
One end of this cable is permanently connected to the **Fan Box (item3)**. The other end has a clear plastic connector called an RJ12 Plug which fits into the **FANS** socket of the **Controller Unit** (item 1).
9. **8 wire 'Wall Switch' Cable**
This is supplied as a 15 metre long patch cable with a clear plastic connector on each end called an RJ45 Plug. It plugs into the rear of the **Wall Control Switch (item 2)**, usually passes through the wall cavity, and eventually plugs into the side of **the Main Controller Unit** in the socket labeled **CONTROL**.
10. **6 wire flat 'Air Flow Select' Cable**
One end of this cable is permanently fixed to the **Air Flow Selection Box (item 5)**. The other end has a plastic connector called an RJ12 Plug which inserts into the **DUCT1** socket of the **Main Controller Unit**. (**ensure that it is NOT inserted into the DUCT2 socket which is a reserved input for advanced systems where more than one Air Flow Selection Boxes are used**)
11. **2 wire Black Solar Panel Cable**
This is a pre-wired patch cable with two spade connectors on one end that fit onto the **Solar Panel Unit (item 4)**. The other end has a round D.C. plug that fits into the **SOL** socket of the **Main Controller Unit**. Correct polarity is important for this connection so ensure that the spade terminal labeled **NEG** connects to the Negative terminal of the Solar Panel. If the connection has been successful and at least some sunlight is shining on the Solar Panel, then the green confirmation light above the SOL socket on the Main Controller Unit should glow.
12. **Temperature Probe Cable (if fitted)**
This is a small 4-wire flat cable with RJ11 connectors that connects between the **Air Flow Selection Box** (item 5 or 13) and a small ambient temperature probe box. It takes air flow temperature readings and passes this information back to the Main Controller Unit.
13. **Battery Switch**
When the controller unit first arrives from the factory, the internal 12V battery is in the OFF position to prevent the battery from being discharged. When the installation has been installed and is ready for use, this switch should then be placed in the ON position.
14. **Integrated Fan & Duct control 'Snail' unit**
This is an alternate assembly for some roof-mount installations where the fan box and duct control box has been integrated into a single unit. It has 3 connections. There is the Fan and Servo cables on standard RJ12 plugs and an optional temperature probe input on a smaller RJ11 connector. (refer to the photo on the previous page for details of this connection.)

TESTING THE SYSTEM CONNECTIONS

If all of the above connections have been successfully made, then the system should operate normally. Here are a sequence of integrity checks to confirm normal operation.

STEP 1. CHECKING THE POWER INDICATORS ON THE MAIN CONTROL UNIT

Provided there is at least some sunlight on the Solar Panel, when it is connected to the Main Control Unit (via Item 11) then the green LED indicator on the side of the side of the unit should glow. Likewise, if the D.C. Plug Pack, is correctly plugged in, it too should produce a green glow above the corresponding socket. Refer to **Troubleshooting Section 1** if the green indicators fail to glow. If a fan is immediately enabled by the operator after the Solar Panel is connected, (hi or low speed) it may take 20 seconds for the system to measure the presence of usable sunlight before a fan will start.

STEP 2. CHECKING THE WALL CONTROL SWITCH.

This is an important test to make because it proves the integrity of the 8-wire patch cable, the basic operation of the Main Control Unit and the Wall Switch itself. The logic circuit of the Main Control Unit should be running whenever the battery is connected, or the Solar Panel is connected or the optional 12V Power Supply is connected.

When either button of the Wall Switch is pressed, there should be a BEEP sound coming from the rear of the wall plate and the three red LED indicators should go on and off with various button presses. If this fails to happen, check **Troubleshooting Section 2**.

STEP 3. CHECKING FAN INTEGRITY

If Steps 1 and 2 pass ok, (and there is sufficient sunlight) pressing the **FAN** button on the Wall Control Switch should produce a single 'Beep' and bring the red **Fan Low** indicator **ON**. At this point TWO of the FOUR fans should be operating, which is the low-speed mode. If the button is pressed a second time, a brief double-beep should be heard, the **Fan High** indicator should come **ON** and all four fans should then operate. Pressing the button a third time should produce a long beep and the fans should revert back to an OFF state. If any of these steps does not take place, refer to **Troubleshooting Section 3**.

Note that the act of manually pushing the fan control button to Low or High position will force the system to operate in this mode. The control system may suspend fan operation if it believes that there is insufficient sunlight available. (Fan LED will slowly flash)

Also note that if the sunshine level is something less than maximum, there may be a *drop* in volume of the fan heard by the operator when the fans change from Low to High settings. This is because when all four fans come on line, the extra load may cause a *drop* in voltage from the solar panel on a cloudy day, thus reducing the peak speed of the fans.

STEP 4. CHECKING AIR FLOW SELECTOR BOX INTEGRITY

This test checks to see if the flap in the **Air Flow Selector Box** is successfully changing state from OPEN to CLOSED so that the Heating and Cooling modes of operation may be selected by the operator.

When power is first applied to the Main Control Unit (from whatever power source is available) the Air Flow Selector Box should enter the HEATING mode and the red HEAT ON indicator should glow. (as heating is the most commonly used mode of operation) By pressing the HEAT / COOL button on the Wall Control Switch, the should turn the red LED indicator OFF and the air flow selector box should move to the second position. If someone is reasonably close to this unit, they should be able to hear the servo motor moving the control flap to the new position every time the Heat / Cool button is pressed. If the fan is running, a shift in temperature should be noticeable on the duct outlet after a short period of time. If this event fails to take place refer to **Troubleshooting Section 4** for advice.

TROUBLESHOOTING SECTION

SECTION 1

CHECKING THE INTEGRITY OF THE SOLAR PANEL AND D.C. SUPPLY

These items have been grouped together because they operate and connect in a similar manner, which is providing D.C. power to the Main Control Unit.

Provided there is even a small amount of sunlight, attaching the solar panel cable (Item 11) should produce a green glow from the status LED indicator on the side of the Main Control Unit. If the cable has accidentally been reversed at the solar panel by the installer, no damage will be done to the electronics, but the green indicator will not light.

If a simple volt meter or multimeter is available, then placing the positive (red) lead of the meter inside the centre pin of the DC Plug, and holding the negative lead to the shiny outside of the plug, should provide a reading of around 17 to 22V DC, as the panel is not under any load. If the reading is a 'minus figure (-17V to -22V) then it is likely that the wires have been reversed at the panel. (the centre pin should always be the 'positive' connection.

If the DC supply is available, then it can be tested in the same way with a voltmeter, except the reading would be closer to 12V D.C. provided that the power supply has been successfully connected to a 240V source.

If the Solar Panel or power supply is intact and correctly connected and it fails to produce a green LED indicator glow when plugged in, then the Solar Panel or supply may be defective and a replacement unit may need to be requested from the Solar Source distributor.

Note that for the purposes of testing, it is ok to try the DC supply in the Solar Panel socket and vice-versa, but the connections should not be left in this position as the control system measures the voltage on each of these two inputs in a different way.

SECTION 2 – FUNCTIONAL TESTING

WALL CONTROL FAILS TO OPERATE CORRECTLY (PARTIAL FUNCTIONALITY)

Firstly determine if there is any functionality at all. If only ONE of the buttons operates, or there is no beeps with button presses while the LED indicators go on and off, or even if the beeps occur, but one of the LED indicators fails to operate, then it means that the Main Control Unit is running, but one or more of the electrical connections in the 8 wire cable is not making full contact. It is worthwhile pressing the connectors firmly within the sockets to ensure that they are making full contact.

If the cable provided is the flat style with clear plastic connectors, then it is possible that the cable was stretched within the connector during installation and this has interrupted the connection. The problem may be solved by giving the connectors at each end an extra squeeze if the installer has any access to a standard RJ45 crimp tool. If no crimp tool is available, then contact the Solar Source office for a replacement cable assembly (Item 9). It is also possible that the connectors are intact, but the cable itself has been crushed or partially severed perhaps within the wall cavity, or against some sheet-metal material near the metal duct work.

The cable integrity can also be proven by trying a short RJ45 patch cable directly between the Wall Plate and the Main Controller that does not pass through wall cavities or suspicious tight places. Any standard network cable with RJ45 plugs on each end can be used for this test. If it is not convenient to request a replacement **Item 9** cable for this test, then standard computer network patch-cable alternatives are available from Jaycar, Dick Smith and most computer accessories shops at low cost and should work quite well. (Note that the cable must be the simple wire-for-wire connection and **not** what is sometimes called a 'crossover cable')

If the partial-functionality fault symptoms are identical when a different cable is tried, then it is possible that the Wall Control Switch itself is defective. The Solar Source distributor should then be contacted for a replacement **Item 2** unit.

WALL CONTROL FAILS TO OPERATE CORRECTLY (ZERO FUNCTIONALITY)

If there is no response at all from pressing buttons on the Wall Control Switch and the 8 wire cable that feeds the wall switch has been proven to be intact, then the problem is likely to be within the Main Control Unit. (it is quite unlikely that both push-button switches in the Wall Control Switch would have failed simultaneously)

First check to see if any power is reaching the Main Control Unit. If either of the two green LED indicators on the side of the Main Control Unit are ON, then there should be enough power from the solar panel or optional 12V DC supply to power the system. If either of these indicators are ON and there is still no response from the Wall Control Switch, then the problem is likely to be within the Main Control Unit and a replacement unit should be requested from the Solar Source distributor. Refer to **Troubleshooting Section 1** if neither of the two green indicators glow when a solar panel or DC supply cable is connected.

SECTION 3 ONE OR MORE FANS FAILS TO OPERATE

When the Wall Control Switch is used to manually place the fan in the High or Low speed condition, and the unit is in the Heating mode, the system will attempt to run the fans. However during this time, if little direct sunlight is reaching the Solar Panel, the fans may not operate. This does not matter greatly as if there is not enough sun to heat the air, then there is little point in operating the fans as well. (The fans never operate from the internal battery as this is only used to maintain the Air Flow Selector box and internal logic circuits.)

It may be difficult to gain direct access to the Fan Unit (item 3) once the system has been installed. Consequently the best way to monitor the fans is to listen to hear if a fan has activated and check for air flow at the output end of the duct.

If no fan activity is heard at all, one other useful check can be made from inside the Main Control Unit. This involves briefly removing the cover of the unit and observing the two indication leds called L3 and L4. When the fans are enabled in the LOW speed mode, only one red indicator should come on. In the HIGH speed mode, both indicators should come on. Note that these indicators only show that a negative power signal is being switched to the fan/s (via wires 2 and 5 of the six wire FAN cable.) The fans still need 12V to operate and this comes from the 12V input of the Solar panel if in the HEAT mode, and from the optional 12V power supply if in the cool mode. This 12V voltage is extended via wires 1 and 6 in the fan cable from the two D.C. supply sockets. It should be present if the green SOL indicator comes ON, showing that a working solar panel has been connected.

If all of these indicators operate and the fans still do not run then check the quality of the connection plug on the 6 wire cable. If this cable has been stretched or not crimped properly then one or both fans may be affected. If a 6 wire telephone style crimp tool is available, then the problem could be repaired by re-crimping the plug or by putting a fresh plug onto it entirely. (these plugs are also referred to as RJ12 plugs)

SECTION 4 THE AIR FLOW SELECTION BOX FAILS TO CHANGE POSITION

There are five items to immediately check if the air duct servo motor refuses to change position when the HEAT / COOL button is operated.

- a. Does the red HEAT ON led go on and off at the **Wall Control Switch** when the button is pressed? (if not, then the control unit is not responding to the request. This is covered in Section 2 of this guide)
- b. Is the **Air Flow Selection Box** plugged into the correct socket? It should be inserted into the **DUCT1** position.
- c. Is the **ON/OFF** switch on the side of the **Main Control Unit** in the ON position? If not, then the internal battery will not provide any power to the servo motor inside the Airflow Box if the solar power or optional D.C. power supply are not present.
- d. Is the servo motor in the **Air Flow Selection Box (item 12)** physically stuck or jammed? At this unit there is a black rectangular box housing the servomotor drive. It is possible to remove the four screws that keep the lid on this box and see if the mechanism tries to operate. If the linkage to the duct flap can be temporarily un-hooked, see if the flap can move freely by hand. Also watch the servomotor and see if it passes through a half-turn when briefly operating the **HEAT / COOL** control button.

- e. Lastly, check the integrity of the 6 wire crimp plug on the end of the Air Flow Selection Box cable. This may be examined and possibly repaired using the same procedure described at the end of **Troubleshooting Section 3**.

There are three wires that feed the servomotor inside the black housing box. **Black, Red and White**. If available, these can be checked with a voltmeter or multimeter. The **Black** is a negative supply wire. The **Red** wire is a +6V supply wire that is only active during the 2 second period that the servo is supposed to be moving. (a battery saving feature) The **White** wire is a pulsing digital control wire where commands are sent to tell the servomotor to move to a particular position.

SECTION 5

THE INTERNAL 12V BATTERY FAILS TO HOLD A CHARGE

The internal 12V battery should have a working voltage of between 12 and 14 volts during normal use. It is charged by the solar panel under control of the microprocessor chip inside the Main Control Unit. Normally, if a fan is left enabled in Hi or Low speed, the battery should have enough energy to flash the LED on the wall control switch all night. If at some stage during the evening, the wall plate fails to respond to button presses, then this is a sign that the battery is not functioning correctly (be sure that the green led indicator above the solar socket is ON during sunlight periods. If it is OFF then there may be a problem with the solar panel or solar panel cable.)

If the system is solar-only, it will connect the battery to the solar panel each dawn for 40 minutes via an internal relay contact. If the battery is extremely flat, (perhaps because the solar panel had been disconnected or covered for several days while the battery switch (item 13) was left in the 'ON' position) then it may take some days of the 40 minute dawn charge cycles for the battery charge to return to normal.

The only certain way of checking the battery is by briefly removing the plastic cover on the Main Control Unit and checking for the presence of 12-14V with a volt meter, or by placing a 12V auto style light globe across the battery terminals and looking for a solid glow.

The battery should have a working life span of around four years. If it is not charging, or its terminal voltage falls below 11Volts then the safest course of action is to request a changeover control unit, complete with new battery from the Solar Source service section.

Please note that the battery is not essential for all operations of the system. If sufficient sunlight is present, then the control module can operate the fans quite well from the solar panel source.

If the optional D.C power supply is placed in the CHG socket, then it can power the fans while in the COOL mode, while floating the battery with a minimum charge current.

Solar Source Warranty – Terms & Conditions July 2008

Solar source systems components are constructed to rigid quality control standards and should provide reliable service for many years. A 12 month warranty applies to all Solar Source products from their date of commissioning when fitted by an authorised Solar Source installer, or from date of purchase if equipment is being installed by the customer. However, as it is possible that this system may be installed in situations outside of recommended guidelines the following limitations apply to our warranty.

- Solar Source systems and optional components should be installed in accordance with the installation notes provided. Installations not conforming to these standards may have their warranty voided.
- Warranty is void where electrical control systems have been affected by water, vermin or unreasonable mechanical stress. Reasonable precautions must be taken by the owner to avoid these situations.

Limitations of Liability

- Solar source systems are intended to supplement and reduce the operating costs inherent in existing heating and cooling systems. While continuous operation may be regarded as critical by the owner. If Solar Source systems are being used in this way it is incumbent of the owner to provide their own heating/cooling contingency plan in the event of system malfunction. Our warranty is not extended to losses incurred by an equipment failure beyond the Solar Source hardware itself. Losses including energy bills of other systems, lost time by staff, costs of unauthorised service personnel and costs incurred by hiring or purchasing backup equipment shall not be the responsibility of the Solar Source manufacturer or its distributors.
- Solar Source systems and their optional components should not be used in situations where its failure will present a direct or indirect threat to human health and safety. Use of Solar Source equipment in these situations is entirely at the risk and discretion of the owner or operator and is in no way approved by the Solar Source manufacturers or its distributors.

Replacement parts

Unless prior arrangements have been made with Solar Source Manufacturers or its Distributors, the following policy applies to all replacement parts provided under warranty.

- Replacement parts should be fitted in accordance with installation and service notes.
- Should any replacement parts be sent to a customer location, they will be sent via regular freight or mail services free of charge. If use of a premium courier or postal service is requested by the customer, this may incur a separate fee.
- Replacement parts are sent on strictly on an *Exchange Basis Only*. The defective or unused parts must be returned to the supplier within 14 days of receiving the replacement part. Failure to do so will cause an invoice to the full value of the parts to be sent to the customer. Further warranty support may be suspended until this invoice is paid up, or the parts returned to the Solar Source distributor.

Transport Policy.

- Many Solar Source components are by their nature heavy and expensive to transport. Should a system failure occur Solar Source Manufacturers and its distributors will work hard to restore service effectively and in reasonable time. This may entail telephone support, a visit by a technician, or it may require that various components of the system be shipped back to the manufacturer for service. Should the cause of the fault be positively identified as being beyond normal operating conditions as described in this document, transport and service costs may be charged to the owner of the system at a reasonable market rate.
- Unless special arrangements apply, the costs of transporting equipment returned to the Solar Source manufacturer or its distributor, shall be borne by the customer. Serviced equipment being *returned* to the customer will be sent free of charge
- If any Solar Source equipment is being returned to an authorised Solar Source service location it is incumbent on the owner of the equipment to ensure that the equipment is suitably packed for transport and that the goods are insured against any damage or loss that may occur while the equipment is in transit. (*Some details of preferred packing methods are outlined in the Customer installer guide*)

Limitations of Third Party Servicing

- Solar Source manufacturers and its distributors shall not be liable for costs of service work or travel expenses incurred by third parties except where these arrangements have been approved in advance. If service work is to be attempted by a third party, a full quotation should be obtained in advance and forwarded to Solar Source manufacturers or its distributors. This is necessary to ensure that any warranty service work that is delegated to an external agency or person, must be done at a reasonable rate by competent service staff.